

SUBMITTAL

Honeywell
USA



**PAKISTAN TOBACCO
COMPANY**

PROJECT:



CONSULTANT:

 **FAKHRI** *Brothers*
The Air-Conditioning People

INDEX

1) 2 Way Motorized Valve Size 2-1/2" Specification

Part No. V5328A

2) Actuator

Part No. ML7420



Pressure Reducing Valve SPECIFICATION

Pressure reducing valve with balanced seat Standard pattern with set point scale

Product specification sheet

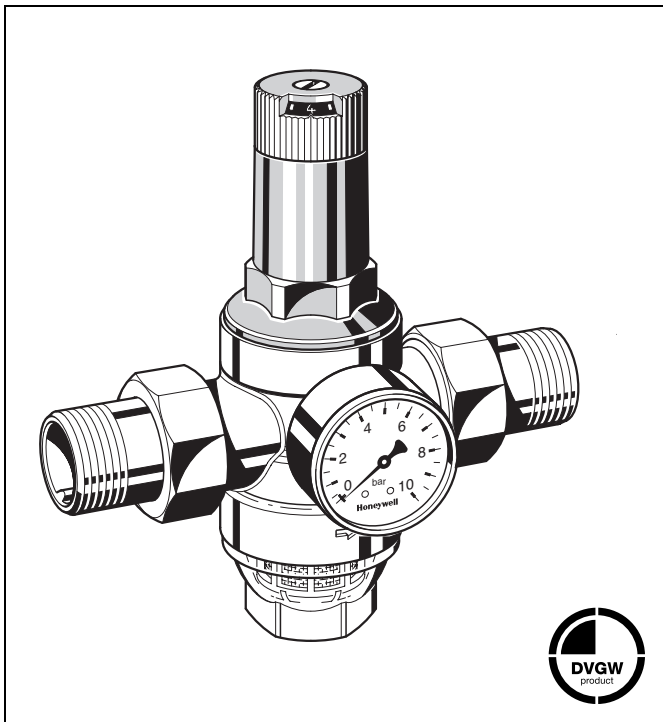

Construction

The pressure reducing valve comprises:

- Housing with G¹/₄" pressure gauge connections on both sides
- Threaded male connections (options A & B)
- Valve insert complete with diaphragm and valve seat
- Fine filter with 0.16 mm mesh
- Spring bonnet with adjustment knob and setting scale
- Filter bowl
- Adjustment spring
- Pressure gauge not included (see accessories)

Materials

- Dezincification resistant brass housing
- Brass threaded connections
- High-quality synthetic material valve insert
- Stainless steel fine filter mesh
- High-quality synthetic material spring bonnet with adjustment knob and setting scale
- Clear synthetic or brass filter bowl
- Spring steel adjustment spring
- Fibre-reinforced NBR diaphragm
- NBR seals

Application

Pressure reducing valves of this type protect household water installations against excessive pressure from the supply. They can also be used for industrial or commercial applications within the range of their specification.

By installing a pressure reducing valve, pressurisation damage is avoided and water consumption is reduced.

The set pressure is also maintained constant, even when there is wide inlet pressure fluctuation.

Reduction of the operating pressure and maintaining it at a constant level minimizes flow noise in the installation.

Special Features

- DVGW approved
- Up to size 1¹/₄" approved for low noise, Group 1 without limitations
- The outlet pressure is set by turning the adjustment knob
- The set pressure is directly indicated on the set point scale
- The adjustment spring is not in contact with the potable water
- The valve insert is of high quality synthetic material and can be fully exchanged
- Integral fine filter
- Also available without fittings
- Easily retrofittable to convert valve to a reverse-rinsing filter combination
- Can be retrofitted with an inlet non-return valve
- Inlet pressure balancing - fluctuating inlet pressure does not influence outlet pressure
- Light weight

Range of Application

Medium	Water, compressed air* and nitrogen* in consideration of valid standards (e.g. DIN EN 12502)
Inlet pressure	max. 16 bar with clear filter bowl max. 25 bar with brass filter bowl
Outlet pressure	1.5-6.0 bar

Technical Data

Operating temperature	Maximum 40 °C with clear filter bowl Maximum 70 °C with brass filter bowl
Minimum pressure drop	1.0 bar
Connection size	1/2" bis 2"

* As part of an installation being approved according to PED requirements, this product must also be certified.

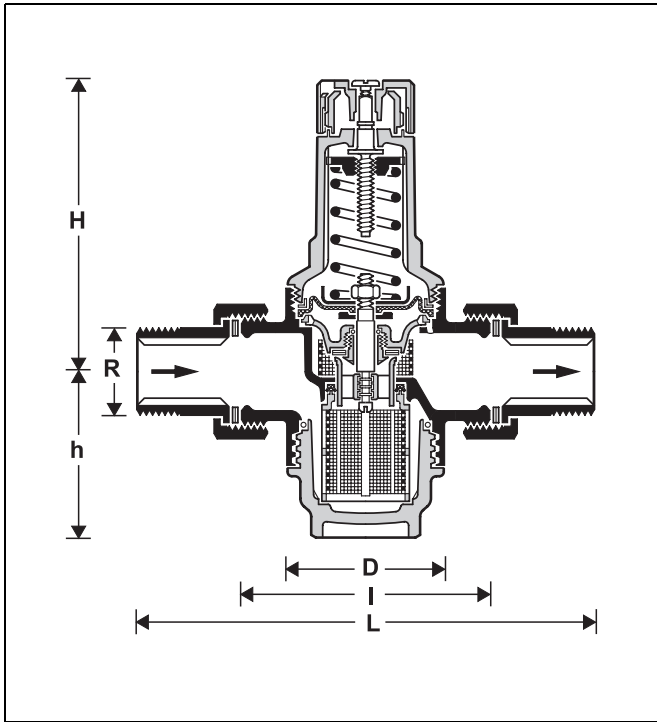

Method of Operation

Spring loaded pressure reducing valves operate by means of a force equalising system. The force of a diaphragm operates against the force of an adjustment spring. If the outlet pressure and therefore diaphragm force fall because water is drawn, the then greater force of the spring causes the valve to open. The outlet pressure then increases until the forces between the diaphragm and the spring are equal again.

The inlet pressure has no influence in either opening or closing of the valve. Because of this, inlet pressure fluctuation does not influence the outlet pressure, thus providing inlet pressure balancing.

Options

- D06F... A = With threaded male connections, clear filter bowl - up to 40 °C
 - D06F... B = With threaded male connections, brass filter bowl - up to 70 °C
 - D06F... E = Without fittings, with clear filter bowl - up to 40 °C
- Special Versions available on request
- └ Connection size

Connection size	R	1/2"	3/4"	1"	1 1/4"	1 1/2"	2"
Nominal size diameter	DN	15	20	25	32	40	50
Weight	kg	0.8	1.0	1.4	2.0	3.3	4.5
Dimensions	mm						
	L	140	160	180	200	225	255
	l	80	90	100	105	130	140
	H	89	89	111	111	173	173
	h	58	58	64	64	126	126
	D	54	54	61	61	82	82
kvs-value	m ³ /h	2.4	3.1	5.8	5.9	12.6	12.0
DVGW-Approval No.		DW-6330AT2314					

* Compulsory testing in sizes R 1/2" to R 1 1/4"



Accessories

FN09S HABEDO ® Retrofit filter

Reverse-rinsing filter for retro-conversion to a filter combination unit of pressure reducing valves

M07M Pressure gauge

Housing diameter 63 mm, rear connection thread G¹/₄". Ranges: 0 - 4, 0 - 10, 0 - 16 or 0 - 25 bar. Please indicate upper value of pressure range when ordering

ZR06K Double ring wrench

For removal of spring bonnet and filter bowl

RV277 Inlet check valve

Available in sizes R¹/₂" - 2"

VST06-A Connection set

Threaded connections

VST06-B Connection set

Solder connections

Installation Example

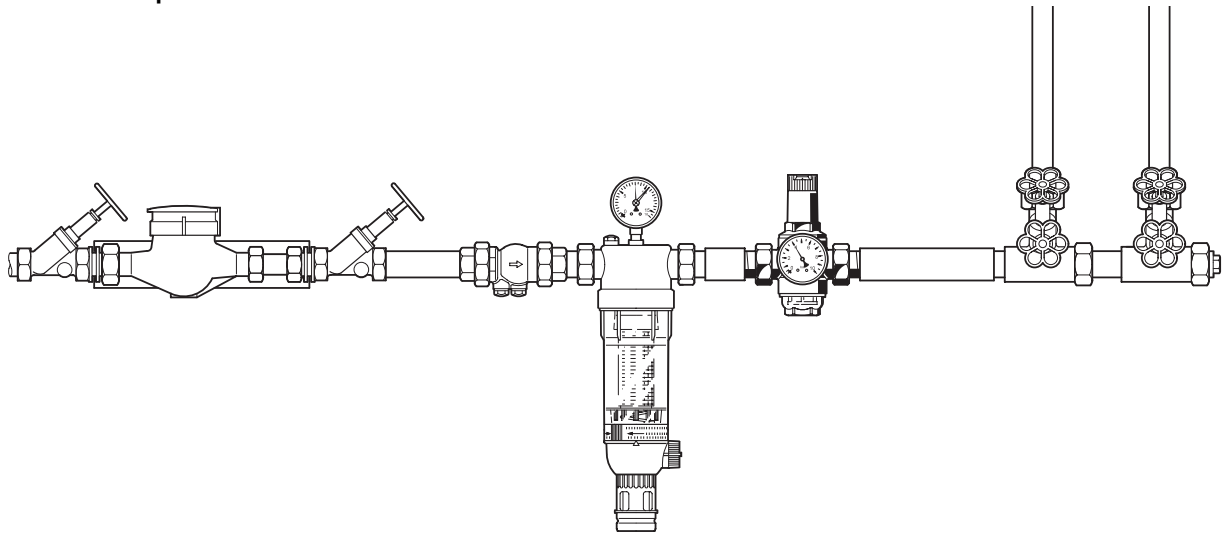

Connection size	R	1/2"	3/4"	1"	1 1/4"	1 1/2"	2"
	DN	15	20	25	32	40	50
W*	mm	55	55	60	60	70	70

* Minimum distance from wall to centre line of pipework

Installation Guidelines

- Install in horizontal pipework with filter bowl downwards.
- Install shutoff valves
- The device downstream should be protected by means of a safety valve (installed downstream of the pressure reducing valve).
- The installation location should be protected against frost and be easily accessible
 - o Pressure gauge can be read off easily
 - o With clear filter bowl, degree of contamination can be easily seen
 - o Simplified maintenance and cleaning
- For residential applications where maximum protection against dirt is required, install a fine filter upstream of the pressure reducing valve
- Provide a straight section of pipework of at least five times the nominal valve size after the pressure reducing valve (in accordance with DIN 1988, Part 5)

Typical Applications

Pressure reducing valves of this type are suitable for all types of household water installations.

Pressure reducing valves can also be used for industrial and commercial applications within the range of their specifications.

Pressure reducing valves should be installed:

- If the static pressure exceeds the maximum permissible value for the system
- As protection against noise if the static pressure at take off points exceeds 5.0 bar (DIN 4109: Noise protection in high buildings)
- If several pressure zones are required when a pressurisation system is used (pressure reducers on each storey of a building)
- If pressure fluctuations in the downstream system must be avoided
- To achieve constant inlet and outlet pressures on pumped pressure boosting systems

Flow Diagram

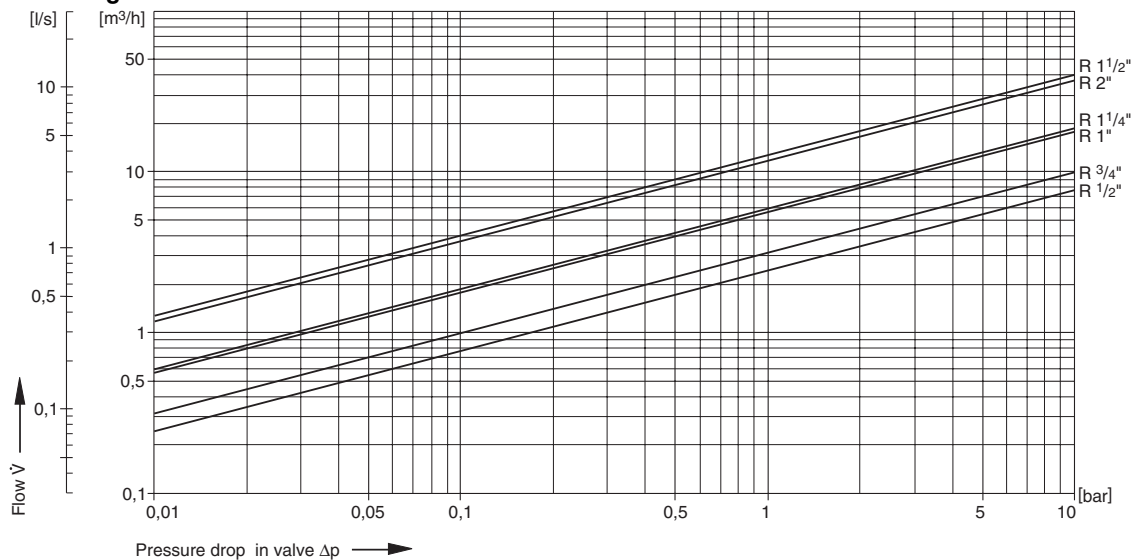

EN0H-1002GE23 R0307 • Subject to change without notice

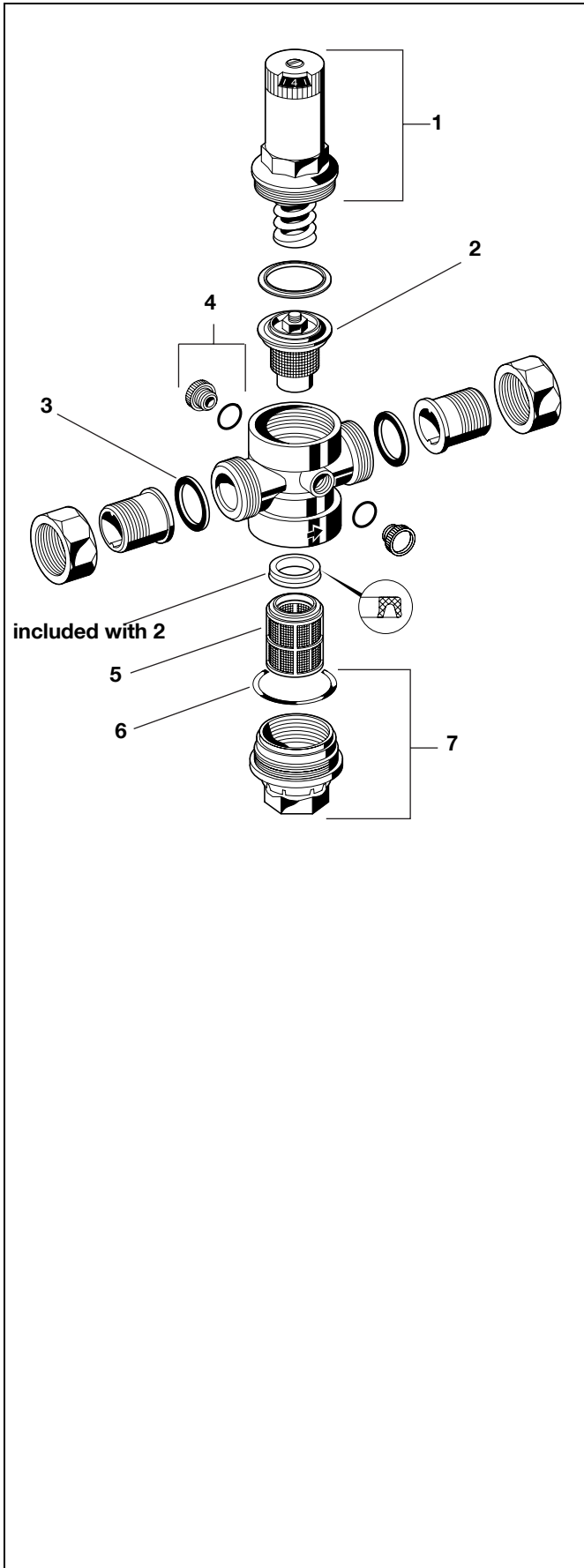

Spare Parts

Pressure Reducing Valve D06F, from 1997 onwards

No.	Description	Dimension	Part No.
1	Spring bonnet complete	1/2" + 3/4"	0901515
		1" + 1 1/4"	0901517
		1 1/2" + 2"	0901518
2	Valve insert complete for D06F (without filter)	1/2" + 3/4"	D06FA-1/2
		1" + 1 1/4"	D06FA-1B
		1 1/2" + 2"	D06FA-11/2
3	Union seal washer (10 pcs.)	1/2"	0901443
		3/4"	0901444
		1"	0901445
		1 1/4"	0901446
		1 1/2"	0901447
		2"	0901448
4	Blanking plug with O-ring R1/4" (5 pcs.)		S06K-1/4
5	Replacement filter insert for D06F	1/2" + 3/4"	ES06F-1/2A
		1" + 1 1/4"	ES06F-1B
		1 1/2" + 2"	ES06F-11/2A
6	O-ring set for D06F (10 pcs.)	1/2" + 3/4"	0901246
		1" + 1 1/4"	0901499
		1 1/2" + 2"	0901248
7	Clear filter bowl with O-ring for D06F	1/2" + 3/4"	SK06T-1/2
		1" + 1 1/4"	SK06T-1B
		1 1/2" + 2"	SK06T-11/2
8	Brass filter bowl with O-ring for D06F	1/2" + 3/4"	SM06T-1/2
		1" + 1 1/4"	SM06T-1B
		1 1/2" + 2"	SM06T-11/2

Automation and Control Solutions

Honeywell GmbH
 Hardhofweg
 D-74821 Mosbach
 Phone: (49) 6261 810
 Fax: (49) 6261 81309
<http://europe.hbc.honeywell.com>
www.honeywell.com

Manufactured for and on behalf of the
 Environment and Combustion Controls Division of
 Honeywell Technologies Sàrl, Ecublens, Route du
 Bois 37, Switzerland by its Authorised
 Representative Honeywell GmbH
 EN0H-1002GE23 R0307
 Subject to change
 © 2007 Honeywell GmbH

Honeywell



Motorized Valve & Actuator SPECIFICATION

V5328A

FLANGED LINEAR VALVE PN16

PRODUCT DATA



GENERAL

These single-seated valves are used for modulating control of hot / chilled water or steam in heating, ventilating and air conditioning systems. Not suitable for use in open-circuit systems with oxygen enrichment.

The valves can be operated by linear actuators ML6420/ML6425, ML7420/ML7425, ML6421/ML7421, or by pneumatic actuators MP953.

FEATURES

- Iron body with flanged end connections
- Low seat leakage rate
- Metal-to-metal seating for long life span
- Self-adjusting packing
- Accurate positioning to ensure state-of-the-art temperature control
- Easy mounting of direct-coupled electric and pneumatic actuators
- Approved according to DIN EN 14597 in combination with ML6425 / ML7425

SPECIFICATIONS

Action	Stem down to close
Nominal pressure rating	PN16
Flow characteristic	Equal percentage, $n_{gl} = 3.4$
Rangeability	50:1
Leakage rate	$\leq 0.05\%$ of k_{VS} up to DN50 $\leq 0.1\%$ of k_{VS} DN65 to DN150
Stroke	20 mm (DN15 to DN 80) 38 mm (DN100 to DN150)
Valve body	
End connections	Flanged per ISO 7005-2
Material	Cast iron (GG25)
Dimensions	See Fig. 1
Trim	
Seat	Stainless steel, replaceable
Stem	Stainless steel
Plug	Stainless steel, skirt-guided
Packing	Spring loaded PTFE cone rings
Medium temperature and pressure	
20 mm	2...120 °C; max. 1600 kPa 120...150 °C; max. 1400 kPa 150...170 °C; max. 1370 kPa
38 mm	2...120 °C; max. 1600 kPa 120...150 °C; max. 1440 kPa 150...200 °C; max. 1280 kPa
Maximum temperature differential in alternating hot/cold water use	60 K

SIZES AND FLOW CAPACITIES

order number	valve size	k _{vs}
V5328A1138	DN15	0.25
V5328A1146	DN15	0.40
V5328A1153	DN15	0.63
V5328A1005	DN15	1.00
V5328A1013	DN15	1.60
V5328A1021	DN15	2.50
V5328A1039	DN15	4.00
V5328A1047	DN20	4.00
V5328A1054	DN20	6.30
V5328A1062	DN25	10.00
V5328A1070	DN32	16.00
V5328A1088	DN40	25.00
V5328A1096	DN50	40.00
V5328A1104	DN65	63.00
V5328A1112	DN80	100.00
V5328A1195	DN100	160.00
V5328A1203	DN125	250.00
V5328A1211	DN150	360.00

INSTALLATION

- Water should meet VDI 2035 requirements.
- Do not install valve with stem below the horizontal.
- Fluid flow must correspond with the arrow direction on the valve body.
- The installation of a strainer is strongly recommended.

REPAIR PACKING KIT

Part no.: R 43176754001 (DN15...32)
 R 43176754002 (DN40...80)
 R43176755005 (DN100...150)

ACTUATORS

Electric Actuators

force	600 N	600 N spring return	1800 N	
model	ML6420A ML7420A	ML6425A,B ML7425A,B	ML6421A ML7421A	ML6421B ML7421B
stroke	20 mm			38 mm
size	DN15-80			DN100-150

Pneumatic Actuators

valve size	pneumatic actuator		action		positioner
	model	size	direct	reverse	
DN 15-80	MP953A MP953B	5", 8" 7"	x	x	yes
	MP953C MP953D	5", 8" 7"	x	x	no
DN 100-150	MP953A MP953C	13"	x	-	yes no

DIMENSIONS (MM) VALVE

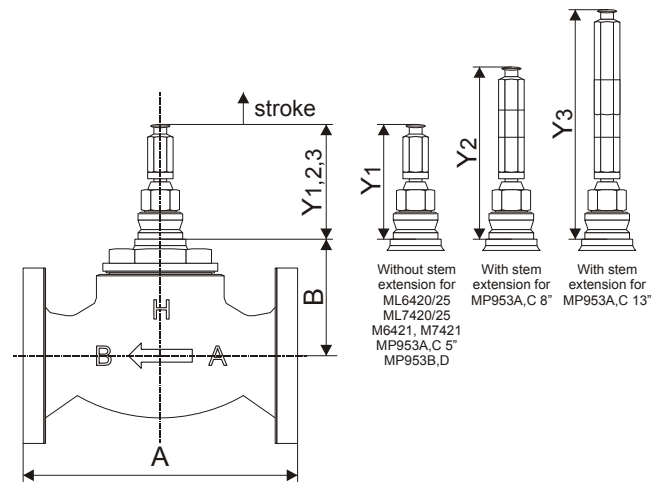

Fig. 1. V5328A

valve size	A	B	adjustment dimension (valve in closed position)		
			Y1	Y2	Y3
15	130	72	89	133	-
20	150				
25	160				
32	180	157			
40	200				
50	230				
65	290	157			
80	310				
100	350				
125	400	157	133	-	190
150	480				

CLOSE OFF PRESSURE RATINGS in kPa

Electric Actuators

actuator		valve size									
model	force	DN15 k _{VS} 0.25 -1.0	DN15 k _{VS} 2.5 -4.0	DN 20/25	DN 32	DN 40	DN 50	DN 65	DN 80	DN 100	DN 125/150
ML6420A, ML6425A,B ML7420A, ML7425A,B	600 N	1600	1000	1000	600	350	200	120	50	-	-
ML6421A,B, ML7421A,B	1800 N	1600	1600	1600	1600	1300	750	500	230	230	90

Pneumatic Actuators

actuator MP953	actuator spring range	air pressure in actuator	valve size										
			DN15 k _{VS} 0.25 -1.60	DN15 k _{VS} 2.5 -4.0	DN 20	DN 25	DN 32	DN 40	DN 50	DN 65	DN 80	DN 100	DN 125/150
C 5"	14...48 kPa (2...7 PSI)	115 kPa	1600	750	750	750	430	260	130	70	30	-	-
A,C 5"	27...76 kPa (4...11 PSI)		1600	430	430	430	240	130	70	-	-	-	-
C 5"	55...83 kPa (8...12 PSI)		1600	240	240	240	120	60	20	-	-	-	-
C 8"	14...48 kPa (2...7 PSI)		1600	1600	1600	1600	1600	1000	760	400	180	-	-
A,C 8"	27...76 kPa (4...11 PSI)		1600	1500	1500	1500	900	560	360	190	80	-	-
C 8"	55...83 kPa (8...12 PSI)		1600	1200	1200	1200	710	440	300	140	60	-	-
D 7"	27...76 kPa (4...11 PSI)	0 kPa	1600	590	590	590	340	200	120	50	15	-	-
B,D 7"	55...90 kPa (8...13 PSI)		1600	1370	1370	1370	810	500	350	160	70	-	-
C 13"	14...48 kPa (2...7 PSI)	115 kPa	-	-	-	-	-	-	-	-	-	620	250
A,C 13"	27...76 kPa (4...11 PSI)		-	-	-	-	-	-	-	-	-	320	120

Pneumatic Actuators

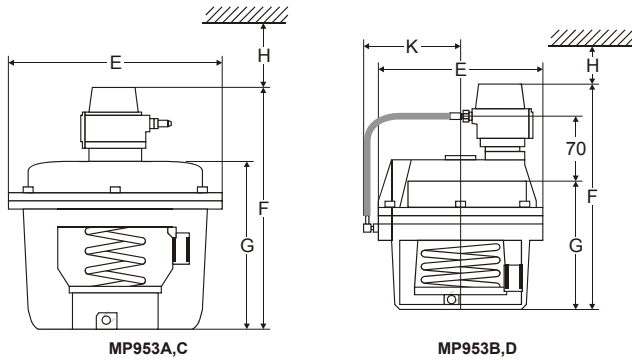

Fig. 2. MP953A,B,C,D (dimensions in mm)

NOTE: V5328A valves up to DN50 in combination with the following actuators are approved according to DIN EN 14597.

Actuator O.S. No.	DIN Registration No.
ML6425A3006 ML6425A3014 ML7425A6008	1F139/08
MP953B5003 MP953D5009	1F12392

Model	E	F	G	H	K
MP953A 5"	130	192	-	120	-
MP953C 5"		-	120		
MP953A 8"	210	237	-	140	
MP953C 8"		-	165		
MP953A 13"	343	327	-	200	
MP953C 13"		-	255		
MP953B	180	242	-	120	107
MP953D		-	137		

Electric Actuators

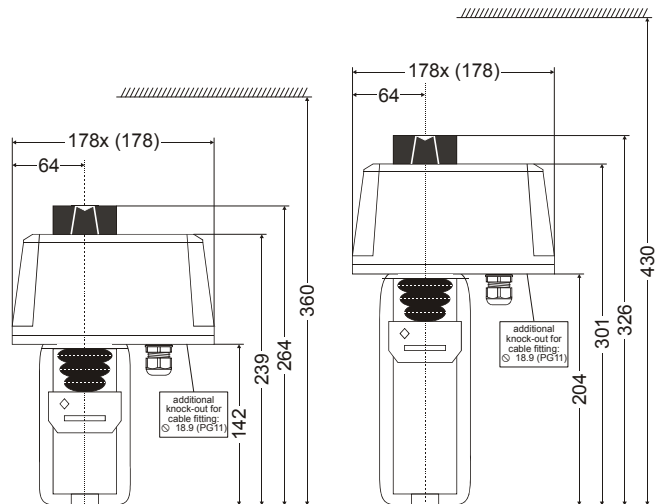

Fig. 3. ML6421A, M7421A (left) and ML6421B, ML7421B (right), dimensions in mm

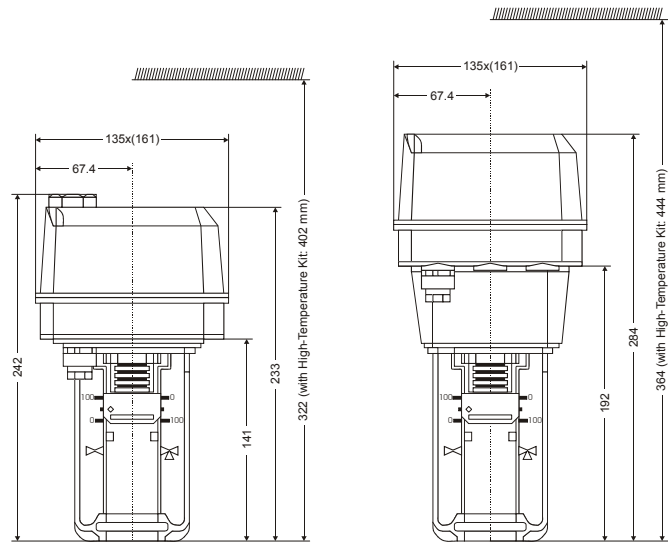

Fig. 4. ML6420A / ML7420A (left) and ML6425A,B / ML7425A,B (right), dimensions in mm



Manufactured for and on behalf of the Environmental and Combustion Controls Division of Honeywell Technologies Sàrl, Rolle, Z.A. La Pièce 16, Switzerland by its Authorized Representative:

Automation and Control Solutions

Honeywell GmbH
 Böblinger Strasse 17
 71101 Schönaich / Germany
 Phone: (49) 7031 63701
 Fax: (49) 7031 637493
<http://ecc.emea.honeywell.com>
 Subject to change without notice. Printed in Germany

EN0B-0291GE51 R0713

ML6420, ML7420 Non-Spring Return Electric Linear Valve Actuators

PRODUCT DATA



FEATURES

- Quick and easy installation.
- No separate linkage required.
- Conduit connector is standard.
- No adjustments required.
- Low power consumption.
- High close-off ratings.
- Force-limiting end switches.
- Manual operator.
- Synchronous motor.
- Corrosion resistant design.
- Maintenance free.
- Direct/reverse acting with ML7420.
- Position feedback signal included with ML7420.
- Selectable 0 to 10 Vdc or 2 to 10 Vdc signal input with ML7420.

APPLICATION

The ML6420 Non-Spring Return Electric Linear Valve Actuators are floating control actuators used with controllers that provide a switched or floating single-pole double-throw (spdt) output. These actuators operate standard Honeywell valves in heating, ventilating, and air conditioning (HVAC) applications.

The ML7420 Non-Spring Return Electric Linear Valve Actuators are modulating control actuators used with controllers that provide an analog output of 0 to 10 Vdc or 2 to 10 Vdc. These actuators operate standard Honeywell valves in HVAC applications. An internal selector plug can be used to reverse the direction of action.

Contents

Application	1
Features	1
Specifications	2
Ordering Information	2
Installation	3
Operation	6
Checkout	7



SPECIFICATIONS

Models:

Model	Run Time in sec at 60 Hz	Stroke in in. (mm)	Description
ML6420A	30 or 60 ^a	3/4 (20)	Electric Linear Valve Actuator
ML7420A			

^a Dependant on actuator model.

Dimensions: See Fig. 1.

Weight: 2.9 lb (1.3 kg).

Electrical Ratings:

Power Input: 24 Vac \pm 15%, 60 Hz.

Power Consumption:

ML6420: 6 VA maximum at 24 Vac.

ML7420: 7 VA maximum at 24 Vac.

Signal Source Output Resistance: 1K ohm maximum.

Signal Load: 1 mA maximum.

Ambient Ratings:

Temperature:

Ambient: 14°F to 122°F (-10°C to +50°C).

Storage: -40°F to +158°F (-40°C to +70°C).

Maximum Valve Medium: 300°F (150°C).

Humidity: 5 to 95 percent relative humidity, noncondensing.

Stem Force: 135 lbf (600N).

Signal Inputs (Supply Voltage Between Terminals):

ML6420:

B and 24 Vac: Drives valve stem down.

W and 24 Vac: Draws valve stem up.

ML7420: 0 to 10 Vdc or 2 to 10 Vdc.

Actuator Material:

Cover: ABS-FR plastic.

Base: PBTP-FR plastic.

Yoke: Diecast aluminum.

Actuator Stroke: 3/4 in. (20 mm).

Close-off Pressure Ratings: See Table 1.

Protection Standard: IP54.

Approvals:

Canadian Standards Association Listed.

Underwriter's Laboratories, Inc. UL94-5V Flame Retardant.

Meets CE requirements.

Cable entry: Conduit connector and one knockout on case.

Accessories:

43191679-111 Single Auxiliary 10K ohm Potentiometer.

43191679-112 Single Auxiliary 220 ohm Potentiometer.

43191680-105 Dual Auxiliary Switch (for 24 Vac use *only*).

43196000-001 High Temperature Kit (1/2 to 3 in. valves).

Increases temperature range high-end to 428°F (220°C).

Table 1. Close-off ratings for ML6420, ML7420 Electric Linear Valve Actuators and Honeywell Valves (psi).

Type	Valve	1/2 in.	3/4 in.	1 in.	1-1/4 in.	1-1/2 in.	2 in.	2-1/2 in.	3 in.
Flange	V5011A	—	—	—	—	—	—	28	16
	V3350/3351/3450/3451	—	—	—	—	—	—	21	14
	V5013B,C; V3360/3361/3460/3461	—	—	—	—	—	—	21 ^a	14 ^a
NPT	V5011F,G	150 ^b	150 ^b	150 ^b	134 ^b	77	49	28	16
	V5011H,J	150	150	150	145	—	—	—	—
	V5011N1xxx, V5011N3xxx, V5013N	230	230	163	104	67	37	—	—
	V5011N2xxx	100	100	100	100	—	—	—	—
	V5013F	150	150	150	126	77	49	—	—

^aRepresents maximum pressure difference between the outlet and either of the two inlets.

^bDo not exceed 100 psi with V5011G valves used in steam applications.

ORDERING INFORMATION

When purchasing replacement and modernization products from your TRADELINE® wholesaler or distributor, refer to the TRADELINE® Catalog or price sheets for complete ordering number.

If you have additional questions, need further information, or would like to comment on our products or services, please write or phone:

1. Your local Honeywell Automation and Control Products Sales Office (check white pages of your phone directory).
2. Honeywell Customer Care
1885 Douglas Drive North
Minneapolis, Minnesota 55422-4386

In Canada—Honeywell Limited/Honeywell Limitée, 35 Dynamic Drive, Scarborough, Ontario M1V 4Z9.

International Sales and Service Offices in all principal cities of the world. Manufacturing in Australia, Canada, Finland, France, Germany, Japan, Mexico, Netherlands, Spain, Taiwan, United Kingdom, U.S.A.

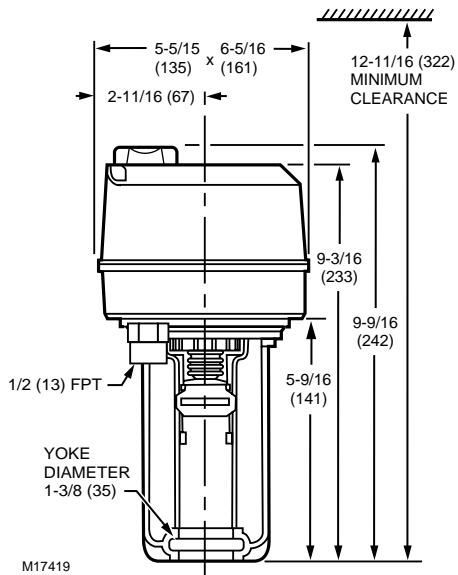

Fig. 1. Approximate dimensions of ML6420, ML7420 Electric Linear Valve Actuator in in. (mm).

INSTALLATION

When Installing this Product...

1. Read instructions carefully. Failure to follow them could damage the product or cause a hazardous condition.
2. Check ratings and description given in the specifications to make sure the product is suitable for your application.
3. Installer must be a trained, experienced service technician.
4. After installation is complete, check out product operation as provided in these instructions.



CAUTION

Electrical Shock or Equipment Damage Hazard.
Can shock individuals or short equipment circuitry.
 Disconnect power supply before installation.

Location

Install the actuator in a location that allows enough clearance for mounting accessories and for servicing.



CAUTION

Equipment Damage Hazard.
Can damage actuator due to condensation or a valve gland leak.
 Install the actuator in a position above horizontal.

Mounting

1. Place the actuator on the valve with the U-bolt around the valve collar. See Fig. 2.
2. Place the U-bolt against the valve collar and secure the actuator to the valve by turning each U-bolt nut clockwise.

NOTE: To assure even pressure on the collar, first tighten the nuts finger-tight and then alternate turning each U-bolt nut until both are snug.

3. Push aside the stem button retaining clip and hold. See Fig. 3.
4. Lift valve stem until the head of the valve stem button is inside the large slot of the stem button retaining clip on the actuator.
5. Release the stem button retaining clip to secure the stem button. Check to make certain the stem button is secured by the retaining clip.
6. Remove the cover from the actuator using a Phillips or crosspoint screwdriver. See Fig. 4.

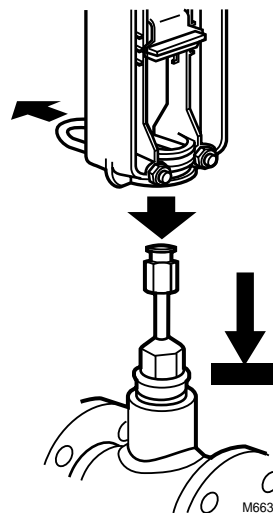

Fig. 2. Attaching actuator to valve collar.

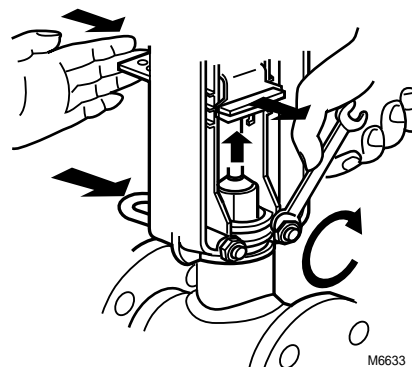

Fig. 3. Securing actuator to valve.

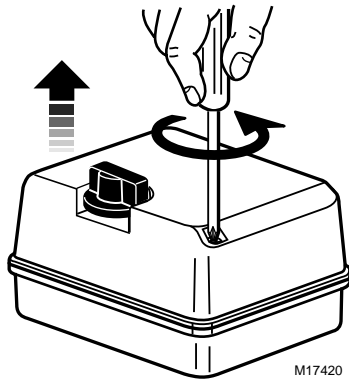

Fig. 4. Removing actuator cover.

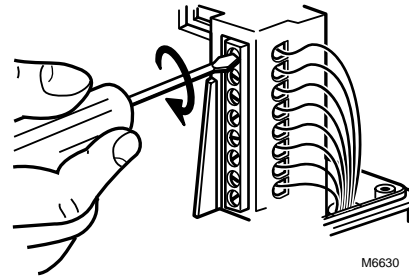

Fig. 5. Connecting power and control wiring.

Wiring

CAUTION

Electrical Shock or Equipment Damage Hazard.
Can shock individuals or short equipment circuitry.
Disconnect power supply before installation.

All wiring must comply with local electrical codes, ordinances and regulations. Voltage and frequency of the transformer used with the actuator must correspond with the power supply and actuator characteristics. See Fig. 6 through 11 for typical wiring hookups.

1. Feed power and control wires through the conduit connector located on the bottom of the actuator case. See Fig. 5.

CAUTION

Equipment Damage Hazard.
Conduit connection or removal can break an unsupported connector.
When removing or attaching conduit, use a wrench to support the motor connector.

2. Using the wiring diagram in Fig. 6, connect power and control wires. Make sure that all wiring is correct.
3. For ML7420 only: Check the selector plugs for proper settings. See Signal Input Failure section for details.
4. When wiring is complete, replace the actuator cover. See Fig. 7.
5. Apply power and control signals to the actuator.

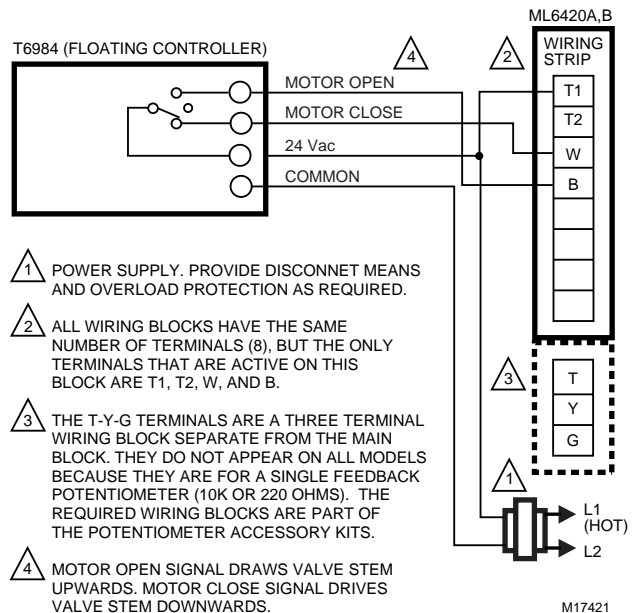

Fig. 6. ML6420 wiring.

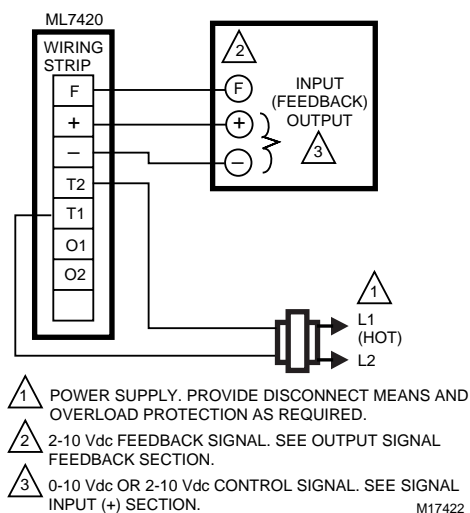
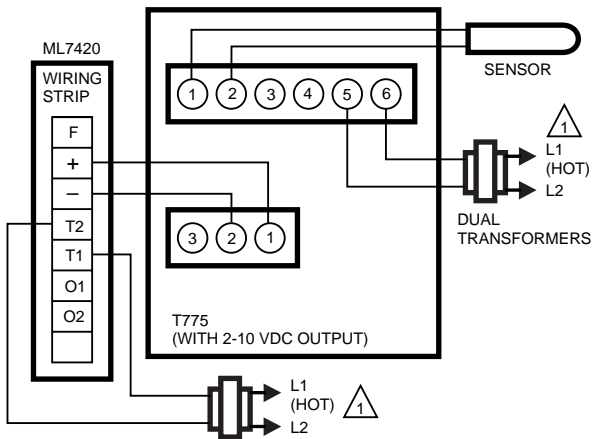

Fig. 7. ML7420 wiring using feedback output from a controller with a common transformer.



1 POWER SUPPLY. PROVIDE DISCONNECT MEANS AND OVERLOAD PROTECTION AS REQUIRED.

M17423

Fig. 8. ML7420 wiring using a 2 to 10 Vdc control signal and separate transformers.

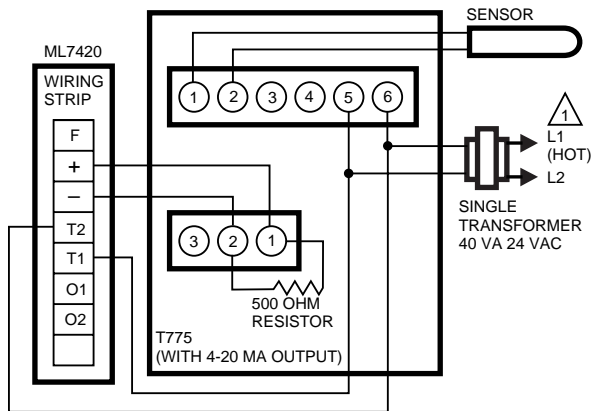

1 POWER SUPPLY. PROVIDE DISCONNECT MEANS AND OVERLOAD PROTECTION AS REQUIRED.

M17426

Fig. 11. ML7420 wiring using a 4 to 20 mA control signal and a common transformer.

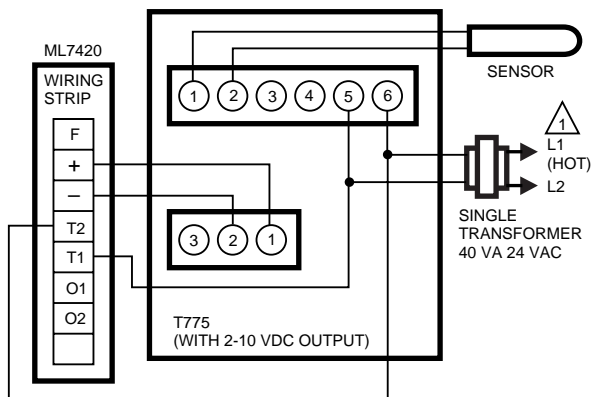

1 POWER SUPPLY. PROVIDE DISCONNECT MEANS AND OVERLOAD PROTECTION AS REQUIRED.

M17424

Fig. 9. ML7420 wiring using a 2 to 10 Vdc control signal and a common transformer.

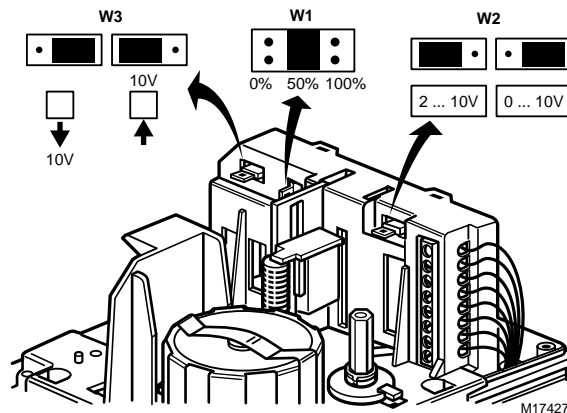

M17427

Fig. 12. Location of W1, W2, and W3 selector plugs.

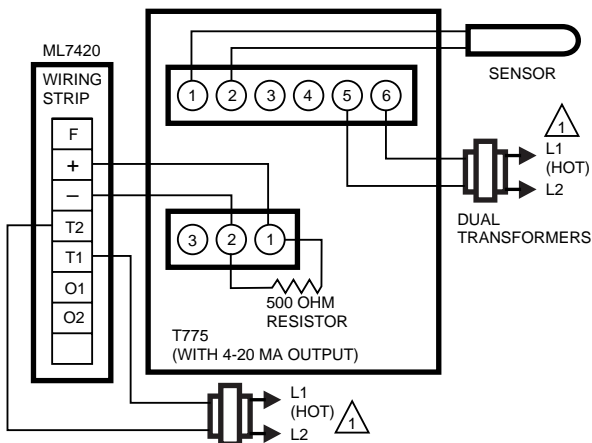

1 POWER SUPPLY. PROVIDE DISCONNECT MEANS AND OVERLOAD PROTECTION AS REQUIRED.

M17425

Fig. 10. ML7420 wiring using a 4 to 20 mA control signal and separate transformers.

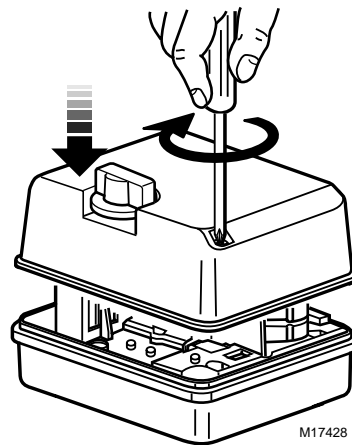

M17428

Fig. 13. Replacing actuator cover.

Auxiliary Potentiometers

The 43191679 Auxiliary Potentiometers can be used as feedback potentiometers and to provide remote indication of valve position. See the Installation Instructions packed with the potentiometers.

Auxiliary Switches

The 43191680 Dual Auxiliary Switch can be used on both the ML6420 and ML7420 Electric Linear Valve Actuators. Switching points are adjustable over the full length of the actuator stroke; for example, the switch can be used to switch pumps or to provide remote indication of any stroke position. See the Installation Instructions packed with the auxiliary switch.



CAUTION

Equipment Damage Hazard.
Improper voltage damages the auxiliary switch beyond repair.

Use the 43191680 Dual Auxiliary Switch only with 24 Vac applications.

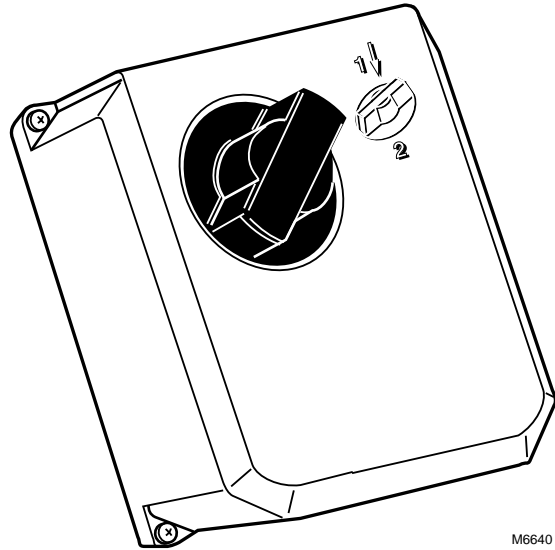

Fig. 14. Manual operator knob.

OPERATION

General

In the actuator, the drive of a synchronous motor is converted into the linear motion of the actuator stem by using a spur gear transmission. A button retainer clip connects the actuator stem to the valve stem.

Manual Operation

The ML6420 and ML7420 are equipped with a manual operator knob (see Fig. 14) to open or close the valve in the event of power failure:

1. Turn off or disconnect the power supply before manually operating the actuator.
2. Push down on the manual operator knob and turn the knob:
 - a. Counterclockwise to drive the stem downward.
 - b. Clockwise to draw the stem upward.

IMPORTANT

Manual operation allows very high closing force that can jam the actuator spindle, exceed the force switch ratings, and stop the motor. After a manual valve close-off operation, release the spindle one turn by turning the manual operator knob. This will ensure automatic disengagement of the manual operator upon power resumption.

NOTE: If the manual operator knob is not pushed in while turned, it will rotate only a short distance before disengaging without power resumption.

ML7420

Signal Input (+)

The analog input signal (+) range is set at the factory to 0 to 10 Vdc. Changing the position of the W2 selector plug sets the range to 2 through 10 Vdc. Selector plugs W1, W2, and W3 are positioned on the back side of the printed circuit board. See Fig. 12 for location of the selector plugs.

Signal Input Failure

Using selector plug W1, the actuator can be set to run to one of three positions in event of a signal failure:

- 0% Actuator position corresponds with 0 or 2 Vdc signal.
- 50% Actuator in mid-position.
- 100% Actuator position according to 10 Vdc signal.

NOTE: W1 is factory set at the mid-position.

Output Signal Feedback (F)

An analog output signal (2 to 10 Vdc) that represents the actual actuator stem position is available at terminal F. It can be used for remote indication of the stem position. When the actuator stem is fully downward, the output signal is 10 Vdc.

When the valve stem is up, the output signal is 0 or 2 Vdc. The output of the signal does not change when the action of the actuator is reversed using W3. See Direction of Action.

Actuator Override

To override the control signal (for freeze protection or similar applications), connect the 24 Vac common (T2) to either terminal O1 or O2. Connecting to terminal O1 fully extends the actuator stem. Connecting to O2 fully retracts the actuator stem.

The control signal (+) is ignored when the override signal is applied to terminal O1 or O2. This override can be achieved with a switch or a relay. See Fig. 15.

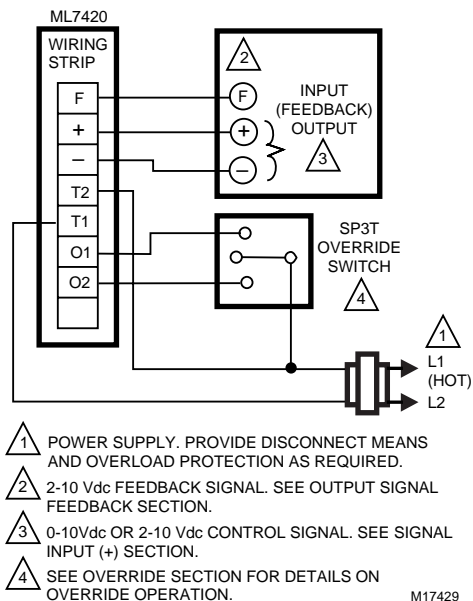

Fig. 15. Connections for overriding control signal to drive ML7420 to a specific position.

Direction of Action

The direction of the actuator action can be changed by repositioning selector plug W3, which is factory set so that the actuator drives the valve stem down on increasing signal and draws the valve stem up on decreasing signal. With the valve stem up, the output signal from the feedback (F) function is either 0 or 2 Vdc. The output of the signal does not change when W3 is used to reverse the actuator action. See Fig. 12.

CHECKOUT

The actuator can be checked out either directly or by using a controller.

Direct Checkout

1. Mount the actuator for the required application; see Installation section.
2. Check the valve position and make sure that 24 Vac is correctly applied to the actuator.
3. Apply the power to the appropriate leadwires to move the valve.
4. If the actuator does not move, make sure the actuator is properly installed/wired.
5. If the actuator installation and wiring are both correct and the actuator does not run, replace the actuator.

Controller Checkout

1. Adjust the setpoint of the controller to call for opening the valve. Observe the actuator.
2. If the valve is closed, it should begin to open.
3. If the valve remains closed, move the setpoint further toward the open setting.
4. If the valve does not move, check for 24 Vac in the actuator power input.
5. If 24 Vac is present and the actuator does not operate, check the voltage across the controller leadwires to determine if the device is miswired.
6. If the wiring is correct, 24 Vac is present on the power input terminals, and the actuator does not run, replace the actuator.

By using this Honeywell literature, you agree that Honeywell will have no liability for any damages arising out of your use or modification to, the literature. You will defend and indemnify Honeywell, its affiliates and subsidiaries, from and against any liability, cost, or damages, including attorneys' fees, arising out of, or resulting from, any modification to the literature by you.

Honeywell

Automation and Control Solutions

Honeywell International Inc.
1985 Douglas Drive North
Golden Valley, MN 55422

Honeywell Limited-Honeywell Limitée
35 Dynamic Drive
Scarborough, Ontario
M1V 4Z9

Honeywell International

Control Products
Honeywell Building
17 Changi Business Park Central 1
Singapore 486073

Honeywell Europe S.A.

3 Avenue du Bourget
1140 Brussels
Belgium

**Honeywell Latin American
Region**

480 Sawgrass Corporate Parkway
Suite 200
Sunrise FL 33325



V5088A

FLANGED LINEAR VALVE PN16 HIGH CLOSE-OFF PRESSURE RATING

SPECIFICATION DATA



GENERAL

These single seated valves are used for modulating control of hot or chilled water or steam in heating, ventilating and air conditioning systems and can be operated by electric linear actuators as ML6421, ML7421, or by pneumatic actuators MP953.

FEATURES

- Cast iron body with flanged end connections
- High Close-off Pressure Rating (1000kPa) Low seat leakage rate
- Metal to metal seating for long life span
- Self adjusting packing
- Accurate positioning to ensure state of the art temperature control
- Directly coupled electric and pneumatic actuators for easy mounting
- Approved according to DIN 32730

SPECIFICATIONS

Action	Stem down to close
Nominal pressure rating	PN16
Plug	Pressure balanced plug
Flow characteristic	Equal percentage
Rangeability	50:1
Leakage rate	≤0.1 % of k_{VS}
Stroke	38 mm
Valve body	
End connections	Flanged per ISO 7005-2
Material	Cast iron (GG25) for PN16
Dimensions	See Fig. 1
Trim	
Seat	Stainless steel, replaceable
Plug	Stainless steel, skirt guided
Stem	Stainless steel
Packing	Spring loaded PTFE V-rings
Medium temperature and pressure	
PN16	2 ... 120 °C: max. 1600 kPa 120 ... 150 °C: max. 1440 kPa 150 ... 200 °C: max. 1280 kPa 200 ... 220 °C: max. 1200 kPa

SIZES AND FLOW CAPACITIES

Order Number	Valve Size		kvs
V5088A1005	PN16	DN100	160.00
V5088A1013	PN16	DN125	250.00
V5088A1021	PN16	DN150	360.00

ACTUATORS

Electric actuators

Actuator (1800N)	Valve Size
ML6421B ML7421B	DN100 - DN150

INSTALLATION

- Water should meet VDI 2035 requirements.
- Do not install valve with stem below the horizontal.
- Fluid flow must correspond with the arrow direction on the valve body.
- The installation of a strainer is strongly recommended.

Pneumatic actuators

Actuator		Valve Size	Direct Acting	Positioner
Model	Size			
MP953A	13"	DN100 -	x	yes
MP953C	13"	DN150	x	no

REPAIR PACKING KIT

Part No. R 43 176 755 - 004
(DN 15 to 65)
R 43 176 755 - 005
(DN 80 to 150)

CLOSE OFF PRESSURE RATINGS IN kPa

Electric actuators

Actuator		Valve Size		
Model	Force	DN100 (kvs 140)	DN125 (kvs 220)	DN150 (kvs 310)
ML6421B, ML7421B	1800 N	1000	1000	1000

Pneumatic actuators

Actuator Model	Actuator Spring Range	Air Pressure in Actuator	Closed Valve Seat	Valve Size		
				DN100	DN125	DN150
MP953C; (13")	14-48 kPa (2-7 PSI)	0 kPa	upper	1000	1000	1000
MP953A,C; (13")	14-48 kPa (2-7 PSI)	115 kPa	lower	1000	1000	1000

DIMENSIONS (mm)

Valve

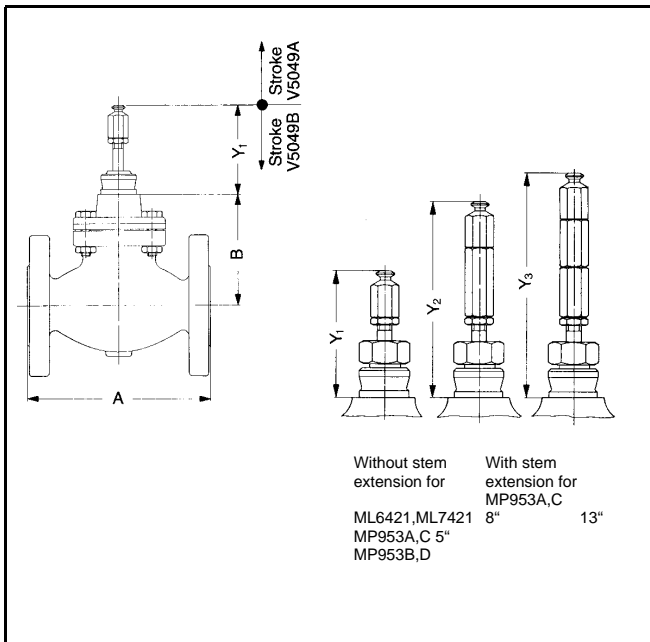

Fig. 1 V5088A

Valve Size	A	B	Adjustment Dimension		
			Y1	Y2	Y3
100	350	181	170	-	227
125	400	219			
150	480	219			
Valve in closed position					

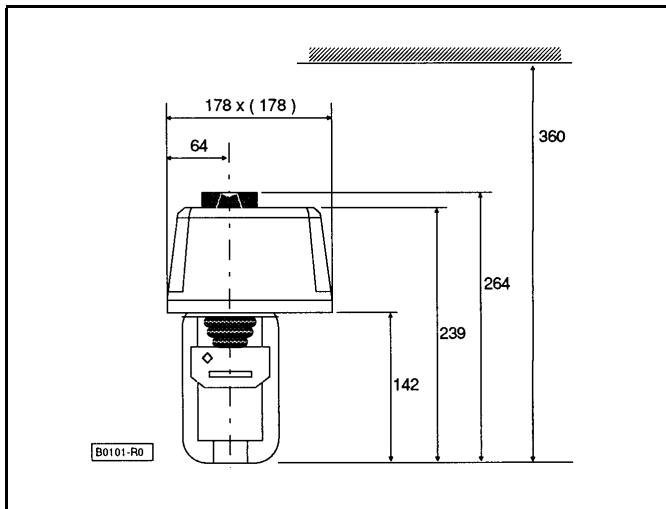

Fig. 2 ML6421A, ML7421A

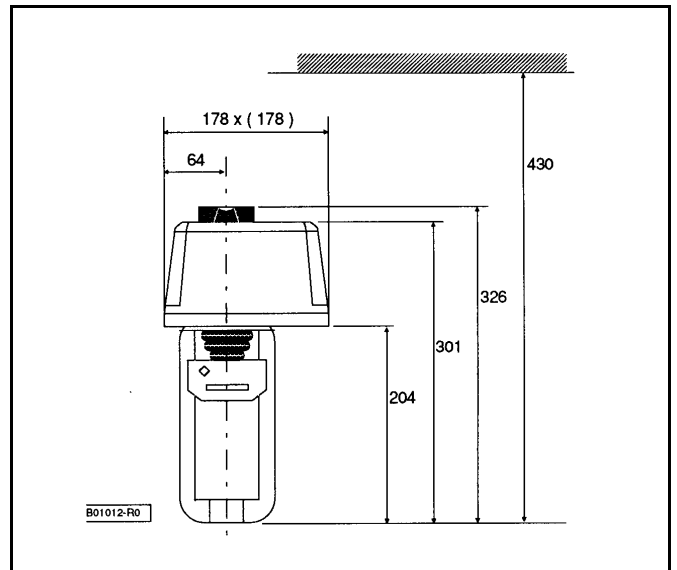

Fig. 3 ML6421B, ML7421B

Honeywell

Home and Building Control Products

Honeywell Regelsysteme GmbH
Honeywellstrasse 2-6
D-63477 Maintal
Phone: (49) 6181 4010
Fax: (49) 6181 45456
<http://europe.hbc.honeywell.com>

Subject to change without notice. Printed in Germany

Manufacturing location certified to **DIN EN**
ISO 9001

EN0B-0433GE02 R0299

ML6421, ML7421 Non-Spring Return Electric Linear Valve Actuators

PRODUCT DATA



FEATURES

- Quick and easy installation.
- No separate linkage required.
- 3/4 in. (20 mm) stroke on ML6421A and ML7421A.
- 1-1/2 in. (38 mm) stroke on ML6421B and ML7421B.
- No adjustments required.
- Accurate valve positioning.
- Low power consumption.
- Selectable 0(2) to 10 Vdc or 0(4) to 20 mA input signal with ML7421.
- Position feedback with ML7421.
- High close-off ratings.
- Direct/reverse acting with ML7421.
- Force-limiting end switches.
- Manual operator.
- Synchronous motor.
- Corrosion-resistant design.
- Maintenance free.
- Conduit connector knockout.

APPLICATION

The ML6421A,B Non-Spring Return Electric Linear Valve Actuators are suitable for use with low-voltage, single-pole double-throw (spdt), Series 60 two-position and floating controllers. These actuators operate standard Honeywell valves in heating, ventilating, and air conditioning (HVAC) applications.

The ML7421A,B Non-Spring Return Electric Linear Valve Actuators are modulating control actuators used with controls that provide an analog output of 0 to 10 Vdc or 2 to 10 Vdc. These actuators operate standard Honeywell valves in HVAC applications. An internal selector plug can be used to reverse the direction of action.

Contents

Application	1
Features	1
Specifications	2
Ordering Information	2
Installation	3
Operation	6
Checkout	7

SPECIFICATIONS

Models:

Model	Stroke in in. (mm)	Run Time in sec at 60 Hz	Description
ML6421A	3/4 (20)	95	Electric Linear Valve Actuator
ML7421A			
ML6421B	1-1/2 (38)	175	
ML7421B			

Dimensions: See Fig. 1.

Weight: 5.1 lb (2.3 kg).

Electrical Ratings:

Power Input: 24 Vac (+10%, -15%), 60 Hz.

Power Consumption: 11 VA maximum at 24 Vac.

Signal Inputs:

ML6421:

24 Vac across T1 and W: Drives stem downward.

24 Vac across T2 and B: Draws stem upward.

ML7421: 0 to 10 Vdc or 2 to 10 Vdc.

Actuator Material:

Cover: ABS plastic.

Yoke and Base: Diecast aluminum.

Stem Force: 405 lbf (1800N).

Close-off Pressure Ratings: See Table 1.

Cable Entry: Two knockout holes for 1/2 in. conduit standard on actuator case.

Ambient Ratings:

Temperature:

Ambient Range: 14°F to 122°F (-10°C to +50°C).

Storage Range: -40°F to +158°F (-40°C to +70°C).

Humidity Range: 5 to 95 percent relative humidity, noncondensing.

Approvals:

Canadian Standards Association Listed.

Underwriter's Laboratories, Inc. UL94-5V Flame Retardant (file E181716).

Meets CE requirements.

Protection Standard: IP54.

Accessories:

43191679-101 Single Auxiliary Potentiometer for ML6421A.

43191679-102 Single Auxiliary Potentiometer for ML6421B.

43191679-103 Dual Auxiliary Potentiometer for ML6421A.

43191679-104 Dual Auxiliary Potentiometer for ML6421B.

43191680-102 Dual Auxiliary Switch (for 24 Vac use *only*).

43196000-001 High Temperature Kit (for actuators with 3/4 in. stroke). Increases maximum temperature to 428°F (220°C).

43196000-102 High Temperature Kit (for actuators with 1-1/2 in. stroke). Increases maximum temperature to 428°F (220°C).

Table 1. Close-off Ratings for ML6421, ML7421 Electric Linear Valve Actuators and Honeywell Valves (psi).

Type	Valve	1/2 in.	3/4 in.	1 in.	1-1/4 in.	1-1/2 in.	2 in.	2-1/2 in.	3 in.	4 in. ^a	5 in. ^a	6 in. ^a
Flange	V5011A,B,C	—	—	—	—	—	—	77	53	29	18	12
	V5011B	—	—	—	—	—	—	—	—			
	V3350/51/60/61;V3450/51/60/61	—	—	—	—	—	—	63 ^b	45 ^b	25 ^b	16 ^b	11 ^b
NPT	V5011F,G	150 ^c	150 ^c	150 ^c	150 ^c	150 ^c	150 ^c	100	61	—	—	—
	V5011N1xxx, V5011N3xxx, V5013N	230	230	230	230	230	126	—	—			
	V5011N2xxx	100 ^d	100 ^d	100 ^d	100 ^d	100 ^d	100 ^d	—	—			
	V5013F	150	150	150	150	150	150	—	—			

^a For use with ML6421B or ML7421B Actuators only.

^b Represents maximum pressure difference between the outlet and either of the two inlets.

^c Do not exceed 100 psi with V5011G valves used in steam applications.

^d Rating is for steam at maximum 100 psi. Ratings for water applications are the same as for the V5011N1xxx.

ORDERING INFORMATION

When purchasing replacement and modernization products from your TRADELINE® wholesaler or distributor, refer to the TRADELINE® Catalog or price sheets for complete ordering number.

If you have additional questions, need further information, or would like to comment on our products or services, please write or phone:

1. Your local Home and Building Control Sales Office (check white pages of your phone directory).
2. Home and Building Control Customer Relations
Honeywell, 1885 Douglas Drive North
Minneapolis, Minnesota 55422-4386

In Canada—Honeywell Limited/Honeywell Limitée, 35 Dynamic Drive, Scarborough, Ontario M1V 4Z9.

International Sales and Service Offices in all principal cities of the world. Manufacturing in Australia, Canada, Finland, France, Germany, Japan, Mexico, Netherlands, Spain, Taiwan, United Kingdom, U.S.A.

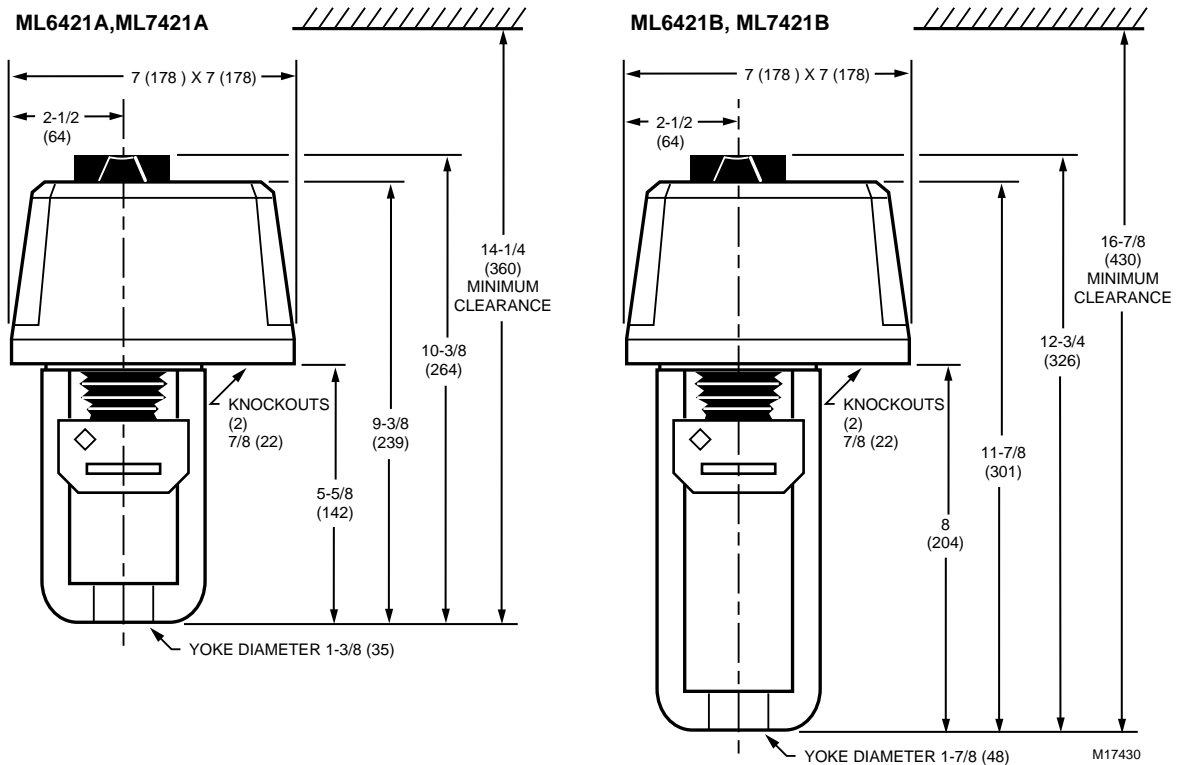

Fig. 1. Approximate dimensions of ML6421, ML7421 Electric Linear Valve Actuators in in. (mm).

INSTALLATION

When Installing this Product...

1. Read instructions carefully. Failure to follow them could damage the product or cause a hazardous condition.
2. Check ratings and description given in the specifications to make sure the product is suitable for your application.
3. Installer must be a trained, experienced service technician.
4. After installation is complete, check out product operation as provided in these instructions.



CAUTION

Electrical Shock or Equipment Damage Hazard.
Can shock individuals or short equipment circuitry.
 Disconnect power supply before installation.

Location

Install the actuator in a location that allows enough clearance for mounting accessories and for servicing.



CAUTION

Equipment Damage Hazard.
Can damage actuator due to condensation or a valve gland leak.
 Install the actuator in a position above horizontal.

Mounting

1. Place the actuator on the valve with the U-bolt around the valve collar. See Fig. 2.

IMPORTANT

When tightening the set screws, first tighten the right set screw. See Fig. 2.

2. Place the U-bolt against the valve collar and secure the actuator to the valve by turning each U-bolt nut clockwise.

NOTE: To assure even pressure on the collar, first tighten the nuts finger-tight and then alternate turning each U-bolt nut until both are snug.

3. Push aside the stem button retaining clip and hold. See Fig. 2.
4. Lift the valve stem until the head of the valve stem button is inside the large slot of the stem button retaining clip on the actuator.
5. Release the stem button retaining clip to secure the stem button. Check to make certain the stem button is secured by the retaining clip.
6. Pull off the manual operation knob.
7. Remove the cover from the actuator using a Phillips or crosspoint screwdriver. See Fig. 3.

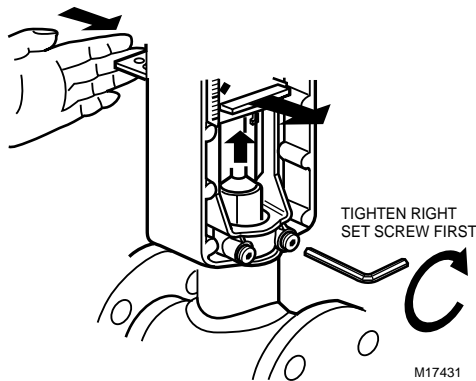

Fig. 2. Attaching actuator to valve.

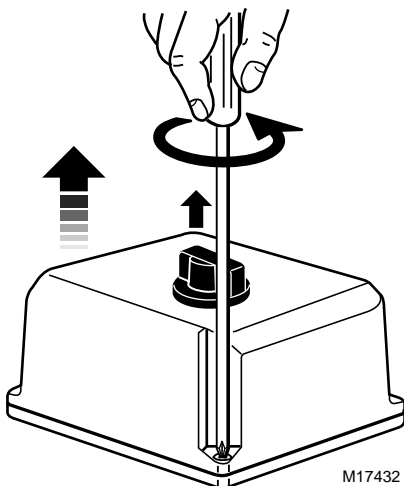

Fig. 3. Removing actuator cover.

Wiring



CAUTION

Electrical Shock or Equipment Damage Hazard.
Can shock individuals or short equipment circuitry.

Disconnect power supply before installation.

IMPORTANT

1. All wiring must comply with local electrical codes, ordinances and regulations.
2. Voltage and frequency of the transformer used with the actuator must correspond with the characteristics of the power supply and those of the actuator.

NOTE: See Fig. 5 through 8 for typical wiring hookups.

1. Feed power and control wires through the conduit connector located on the bottom of the actuator case.



CAUTION

Equipment Damage Hazard.
Conduit connection or removal can break an unsupported connector.

When removing or attaching conduit, use a wrench to support the motor connector.

2. Using the appropriate wiring diagram (see Fig. 5 through 8), connect power and control wires to the actuator. Make sure that all wiring is correct.
3. For the ML7421 only: Check selector plugs for proper settings. See Signal Input Failure section for details.
4. When wiring is complete, replace the actuator cover and control knob (see Fig. 9).
5. Apply power and control signals to the actuator.

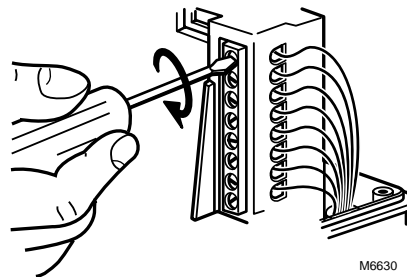

Fig. 4. Connecting wiring to the actuator.

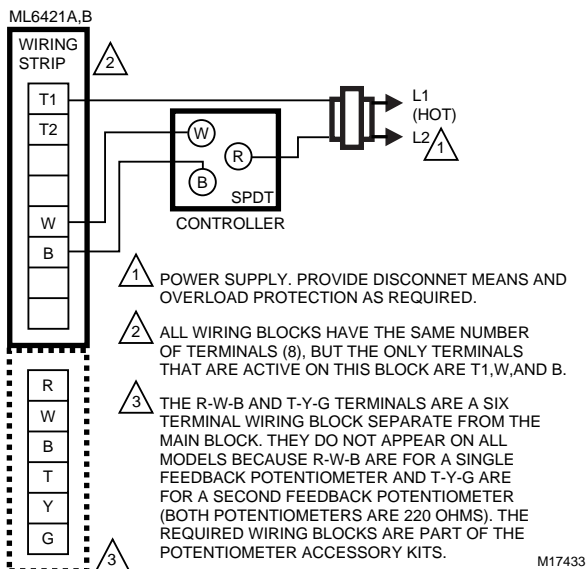

Fig. 5. ML6421 typical wiring diagram.

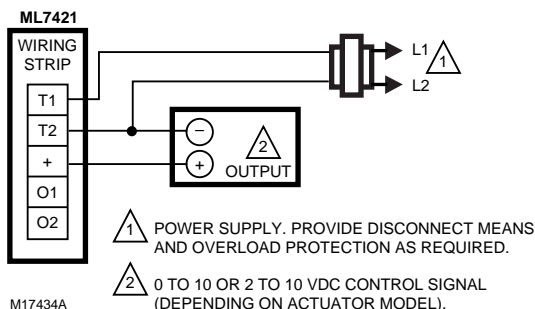

Fig. 6. ML7421 typical wiring diagram.

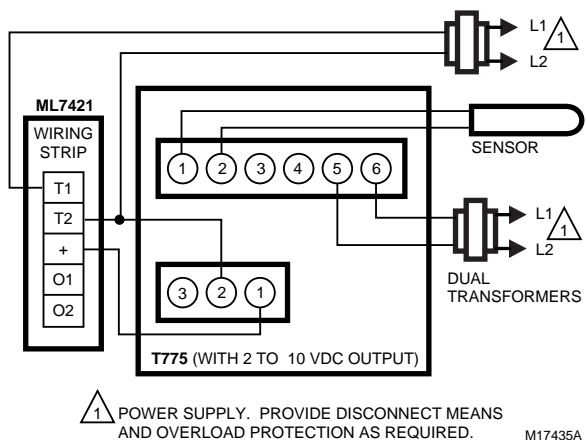

Fig. 7. ML7421 wiring using voltage input control and separate transformers.

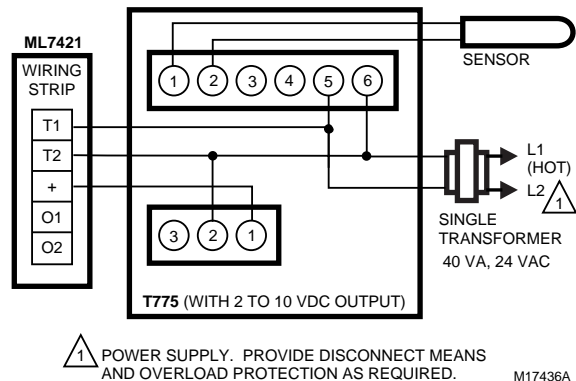

Fig. 8. ML7421 wiring using voltage input control and a common transformer.

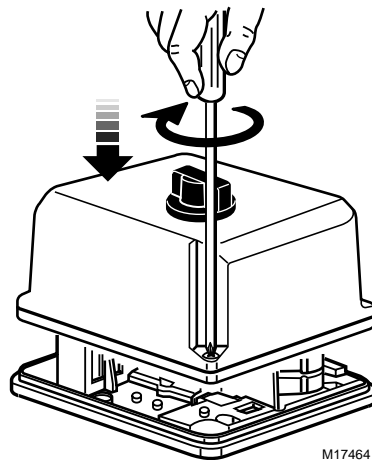

Fig. 9. Replacing actuator cover.

Auxiliary Potentiometers

The 43191679 Auxiliary Potentiometers can be used as feedback potentiometers and to provide remote indication of the valve position. See the Accessories section for part numbers. See Installation Instructions packed with the potentiometers for details.

Auxiliary Switches

The 43191680 Dual Auxiliary Switch can be used on both the ML6421 and ML7421 Electric Linear Valve Actuators. Switching points are adjustable over the full actuator stroke. For example, the switch can be used to switch pumps or to provide remote indication of any stroke position. See the Installation Instructions packed with the auxiliary switch for details.

IMPORTANT

Use the 43191680 Dual Auxiliary Switch only with 24 Vac applications.

OPERATION

General

The drive of the actuator synchronous motor is converted into the linear motion of the actuator stem by using a worm gear transmission. A button retainer clip connects the actuator stem to the valve stem.

The internal force sensor, using installed microswitches, turns off the actuator when the specified stem force is reached.

Manual Operation

The ML6421 and ML7421 are equipped with a manual operator knob (see Fig. 10) to open or close the valve in the event of power failure:

1. Turn off or disconnect the power supply before manually operating the actuator.
2. Push down on the manual operator knob and turn the knob:
 - a. Counterclockwise to drive the stem downward.
 - b. Clockwise to draw the stem upward.

IMPORTANT

Manual operation allows very high closing force that can jam the actuator spindle, exceed the force switch ratings, and stop the motor. After a manual valve close-off operation, release the spindle one turn by turning the manual operator knob. This will ensure automatic disengagement of the manual operator upon power resumption.

NOTE: If the manual operator knob is not pushed in while turned, it will rotate only a short distance before disengaging without power resumption.

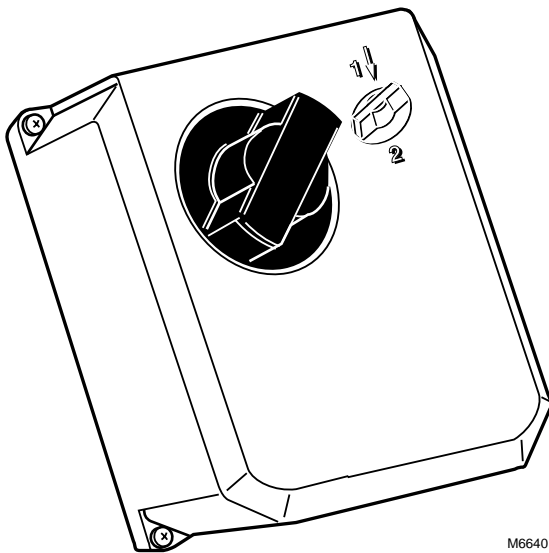

Fig. 10. Manual operator knob.

ML7421

Signal Input Failure

Using selector plug W1, the actuator can be set to run to one of three positions in event of a signal failure:

- 0%: Actuator position corresponds with 0 or 2 Vdc signal.
- 50%: Actuator stem in mid-position.
- 100%: Actuator position according to 10 Vdc signal.

NOTE: If W4 is set to the mA position, the actuator always runs to 0 percent.

Output Signal Feedback (F)

An analog output signal (2 to 10 Vdc) that represents the actual actuator stem position is available at Terminal F. It can be used for remote indication of the stem position.

With the actuator stem fully down, the output signal is 10 Vdc. The output of the signal does not change when the actuator action reverses using W3 or W4 (see Signal Input Failure section and Fig. 11).

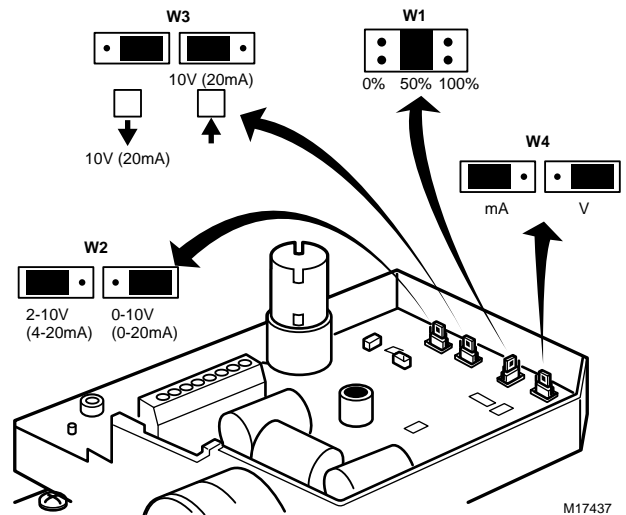

Fig. 11. Location of selector plugs.

Actuator Override

To override the control signal (for freeze protection or similar applications), connect the 24 Vac common (T2) to either terminal O1 or O2. Connecting to terminal O1 fully extends the actuator stem. Connecting to O2 fully retracts the actuator stem.

The control signal (+) is ignored when the override signal is applied to terminal O1 or O2. This override can be achieved with a switch or a relay. See Fig. 12.

Direction of Action

The direction of action can be changed by repositioning the selector plug W3.

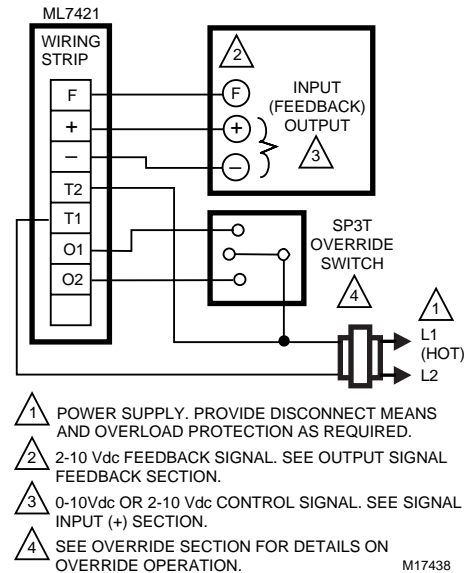

Fig. 12. Connections for overriding control signal to drive actuator to a specific position.

CHECKOUT

The actuator can be checked out either directly or using a controller.

Direct Checkout

1. Mount the actuator for the required application.
2. Check the valve position and make sure that 24 Vac is correctly applied to the actuator.
3. Apply the control signal to the appropriate leadwires to move the valve in the required direction.
4. If the actuator does not move, make sure the actuator is properly installed.
5. If the actuator is correctly installed and does not run, replace the actuator.

Controller Checkout

1. Adjust the setpoint of the controller to call for opening or closing the valve. Observe the actuator.
2. If the valve is closed, it should begin to open.
3. If the valve remains closed, move the setpoint further toward the open setting.
4. If the valve does not move, check for 24 Vac in the actuator power input.
5. If 24 Vac is present and the actuator does not operate, reverse the controller leadwires to determine if the device is incorrectly wired.
6. If wiring is correct, 24 Vac is present on the power input terminals, and the actuator does not run, replace the actuator.

Honeywell

Automation and Control Solutions

Honeywell
1985 Douglas Drive North
Golden Valley, MN 55422

Honeywell Limited-Honeywell Limitée
35 Dynamic Drive
Scarborough, Ontario
M1V 4Z9

Honeywell International

Control Products
Honeywell Building
17 Changi Business Park Central 1
Singapore 486073

Honeywell Europe S.A.

3 Avenue du Bourget
1140 Brussels
Belgium

Honeywell Latin American Region

480 Sawgrass Corporate Parkway
Suite 200
Sunrise FL 33325

