

Insulation

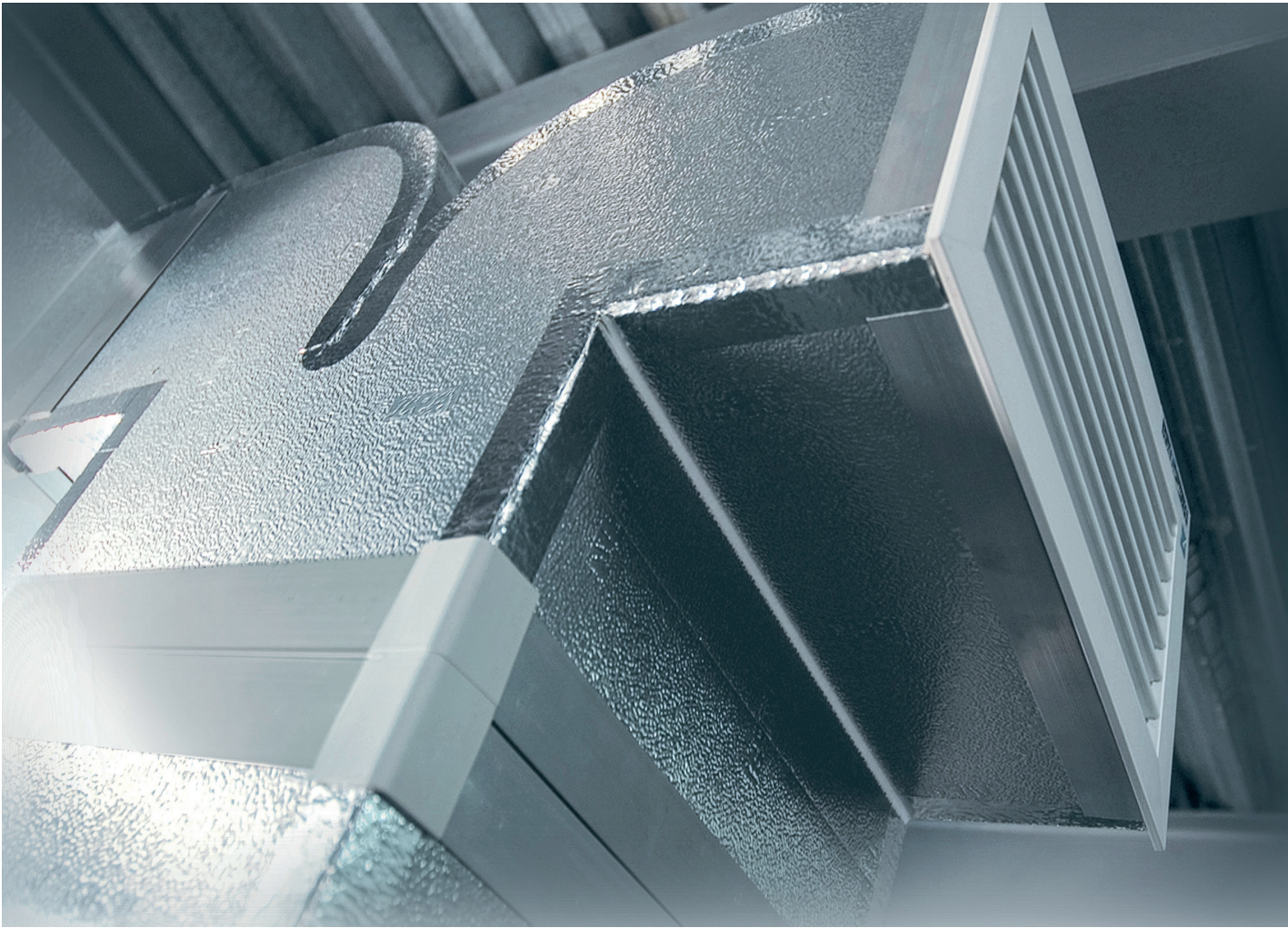

PalDuct™ PIR System

Product Catalogue



Fibre-free
Core



Introduction

Overview

The heating, ventilation and air-conditioning (HVAC) industry is in the midst of a dynamic era. However, air-distribution ductwork, a critical component of HVAC systems, has remained virtually unchanged since the early 1900s.

Several factors have introduced the need to revolutionise HVAC ductwork. Energy use has continued to escalate, and thus the demand for energy reducing solutions has intensified. Requirements for clean air are becoming increasingly prevalent. Speed of construction has become a valuable asset. Floor space and headroom are under constant pressure.

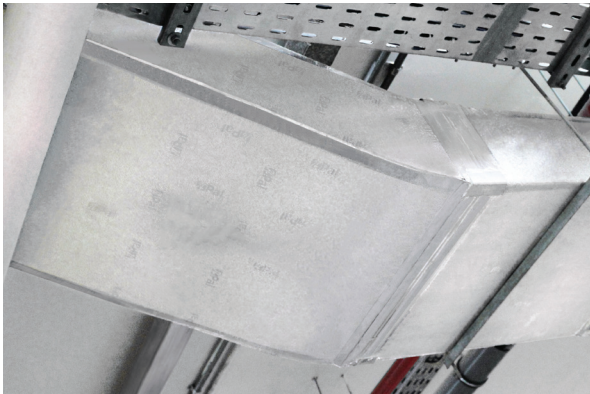

Pal was the first company in the world to introduce the innovative and revolutionary rigid pre-insulated ductwork as an alternative to sheet metal ductwork. It was invented by Claudio Ferraro of Bologna, Italy in 1965.

Kingspan Insulation has proven the value of its products and Kingspan PalDuct has been used in some of the most prestigious projects around the world, due to its known advantages.



Kingspan Insulation has commissioned state of the art manufacturing plants, established workshops in different regions worldwide and also provided specialised and comprehensive training courses conducted by service oriented and experienced trainers well-equipped with the latest technologies, all to ensure quality HVAC ductwork fabrications and installations. This is closely supervised by the representatives from subsidiary companies and sales offices worldwide.

In 2014 Kingspan Group acquired Pal International and assimilated it into its Insulation Division, which subsequently became responsible for the sales and marketing of Kingspan PalDuct products across the globe.

Introduction

What is Kingspan PalDuct Technology?

- Complete line of components and accessories.
- Professional hand tools and automated machinery.
- Specialised training courses for ductwork fabricators.
- “Duct Design Software” to size the ductwork and estimate the material needed.
- Technical Support.



Advantages of Kingspan PalDuct Technology

- Easy to clean.
- CFC/HCFC-free blowing agent.
- Fibre-free insulation core.
- Space saving: flush-fitting installation possible.
- As low as 0.022 W/m.K at 10°C mean temperature (ASTM C518-17/21).
- Fast-track installation compared to traditional installation: rapid erection combined with single-x installation.
- On-site fabrication capability.



Specialised Training & Technical Support

Kingspan Insulation provides specialised and comprehensive training courses to appointed distributors and clients in order to ensure that fabricators carry out the fabrication of Kingspan PalDuct Systems for any project directly on-site, assuring fast and more accurate execution of duct installation requirements.

Kingspan Insulation also provides technical support to appointed distributors and clients in order to ensure the consistent quality of HVAC ductwork fabrication and installations.

Certifications & Compliance

Kingspan PalDuct PIR System is manufactured to the highest standards under a management system certified to ISO 9001: 2015 (Quality Management System), ISO 14001: 2015 (Environmental Management System), ISO 45001: 2018 (Occupational Health and Safety Management System) and ISO 37301:2021 (Compliance Management System).

Product Description

Kingspan PalDuct PIR Panels comprises of rigid thermoset polyisocyanurate (PIR) insulation core. The fibre-free core is manufactured with a blowing agent that has zero ODP (contains no CFC and HCFC) and GWP ≤ 5 .

Kingspan PalDuct Panel Accessories

Polymer/Aluminium Invisible Profile/ Aluminium Joint Profile

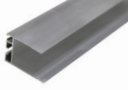
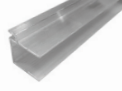
	Thickness	20 mm
	Code	4010 (Aluminium Invisible Profile) 4100 (Polymer)
	Nominal Length	4 m
	Thickness	30 mm
	Code	4040 (Aluminium Joint Profile) 4041 (Aluminium Invisible Profile)
	Nominal Length	4 m

Kingspan PalDuct Eco System Green Colour Polymer/Aluminium Invisible Profile

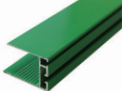
	Thickness	20 mm
	Code	4063 (Aluminium) 4110 (Polymer)
	Nominal Length	4 m



H Bayonet in Polymer

	Thickness	20 mm
	Code	4105
	Nominal Length	4 m



Aluminium Channel

	Thickness	30 mm
	Code	4080
	Nominal Length	4 m

Corner Cover in Polymer

	Thickness	20 mm
	Code	4350
	Thickness	30 mm
	Code	4390



Corner Plate for Invisible Profile

	Thickness	20 mm
	Code	4360
	Thickness	30 mm
	Code	4400

Steel Corner

	Code	4380
---	------	------

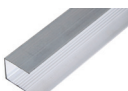
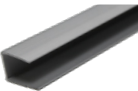
Polymer/Aluminium U Profile

	Thickness	20 mm
	Code	4013 (Aluminium U Profile) 4101 (Polymer U Profile)
	Nominal Length	4 m
	Thickness	30 mm
	Code	4042 (Aluminium U Profile)
	Nominal Length	4 m

Kingspan PalDuct Eco System Green Aluminium U Profile

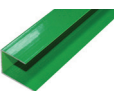
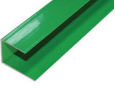
	Thickness	20 mm
	Code	4065
	Nominal Length	4 m
	Thickness	30 mm
	Code	4082
	Nominal Length	4 m

Aluminium Chair Profile

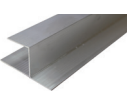
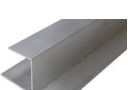
	Thickness	20 mm
	Code	4015
	Nominal Length	4 m
	Thickness	30 mm
	Code	4043
	Nominal Length	4 m

Kingspan PalDuct Panel Accessories

Kingspan PalDuct Eco System Green Colour Cover in Polymer



Code	4355
------	------

Kingspan PalDuct Eco System Green Aluminium Chair Profile

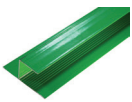

Thickness	20 mm
Code	4067
Nominal Length	4 m

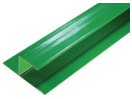

Thickness	30 mm
Code	4083
Nominal Length	4 m

Aluminium F Profile

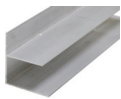

Thickness	20 mm
Code	4017
Nominal Length	4 m

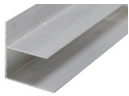

Thickness	30 mm
Code	4044
Nominal Length	4 m

Kingspan PalDuct Eco System Green Aluminium F Profile

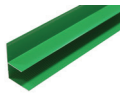

Thickness	20 mm
Code	4069
Nominal Length	4 m

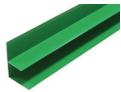

Thickness	30 mm
Code	4084
Nominal Length	4 m

Reinforcement Bar in Aluminium



Thickness	14 mm
Code	4450
Nominal Length	4 m

Reinforcement Disc in Aluminium



Code	4454
------	------

Reinforcement Disc in Polymer



Code	4452
------	------

Duct Support



Code	4455
------	------

Tiger Clip

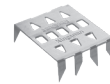

Code	3034
------	------

Cross Fixing Device



Code	4453
------	------

Kingspan PalDuct Panel Accessories

Kingspan PalDuct Sealant



Code	4250
------	------

Kingspan PalDuct PIR Adhesive



Code	4211
------	------

Gasket Self Adhesive



Code	4461
------	------

Aluminium Tape



Width	50 mm
Code	4300

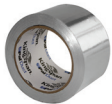

Width	75 mm
Code	4310

Screw for Stiffening Rod



Code	4458
------	------

PIR Pre-insulated Volume Control Damper

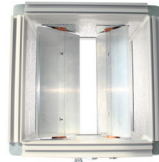

Thickness	20/30 mm
-----------	----------

Phenolic Pre-insulated Volume Control Damper

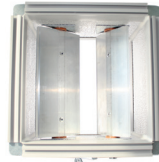

Thickness	20/30 mm
-----------	----------

PIR Pre-insulated Access Door

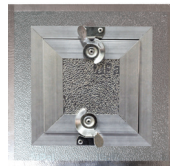

Thickness	20/30 mm
-----------	----------

Phenolic Pre-insulated Access Door

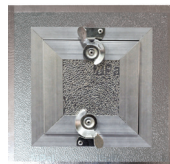

Thickness	20/30 mm
-----------	----------

Automated and Manual Fabrication Equipment

Automated Kingspan Ducting Supercut CNC Machine

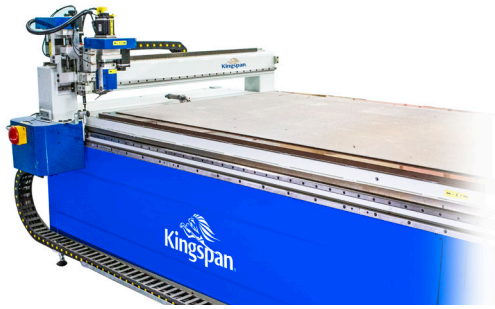

Code	5004
------	------

Manual

A complete set of professional hand tools and manual fabrication equipment has been specifically developed to enable easy fabrication of ductwork. Ease of portability provides the option for on-site fabrication. A full line of automated machinery is also available for high volume ductwork requirements.

Portable Fabrication Table



Length (m)	4 x 1.2
Code	5054

Compass



Code	8008
------	------

Aluminium Clamping Ruler



Length (m)	4
Code	5055



Length (m)	1.2
Code	5056

Portable Fabrication Table



Length (m)	4 x 1.2
Code	5054



Automated and Manual Fabrication Equipment

Kingspan PalDuct Manual Fabrication Tool Kit



Left Cutter	45°
Right Cutter	45°
Double Blade Cutter	90°
Double Blade Cutter - 20 mm	45°
Compass	
Glue Spreading	Manual
Stiff Spatula	Aluminium
Manual Silicone Gun	
Measuring Tape	
Rivet Gun	
Rubber Hammer	
Knife	
Tape Marker	
Code	5053

Square in Aluminium



Size (mm)	1200
Code	5057



Size (mm)	700
Code	5058

Cutter Box



Left Cutter	45°
Right Cutter	45°
Double Blade Cutter 20 mm	45°
Straight Cutter	90°
Code	5082

Manual Bending Machine



Code	5059
------	------

Pneumatic Glue Spreader



Code	5060
------	------

Manual Extended Silicon Tool



Code	5063
------	------

Double Blade Cutter



Size (mm)	20/30 45° Double Blade
Code	5069 (20 mm) 5070 (30 mm)

Single Blade Cutter



Size (mm)	20/30 90° Straight 45° Left 45° Right
Code	(20/30 mm) 5072 (90° Straight) 5068 (45° Left) 5071 (45° Right)

Stiff Spatula



Code	5075
------	------

Glue Spreader Manual



Code	5081
------	------

Tape Marker



Code	5077
------	------

Rubber Hammer



Code	8040
------	------

Kingspan PalDuct Systems Order Guide

20 mm Panel (Internal Use)

To produce 1,000 m² of The Kingspan PalDuct PIR System, the following is a list of material and accessories for a standard construction requirement:

Code	Description	UOM	Approx. Qty.
11010	Panel 4000 x 1200 mm	m ²	1,000
4010	Aluminium Invisible Profile	m	760
4105	H Bayonet in Polymer	m	400
4350	Corner Cover in Polymer	pc	900
4360	Corner Plate for Invisible Profile	pc	1,200
4013	Aluminium U Profile	m	80
4015	Aluminium Chair Profile	m	80
4017	Aluminium F Profile	m	80
4211	Kingspan PalDuct PIR Adhesive	kg	91
4300	Aluminium Tape	roll	150
4250	Kingspan PalDuct Sealant	tube	90

30 mm Panel (External Use)

To produce 1,000 m² of The Kingspan PalDuct PIR System, the following is a list of material and accessories for a standard construction requirement:

Code	Description	UOM	Approx. Qty.
1150	Panel 4000 x 1200 mm	m ²	1,000
4040	Aluminium Invisible Profile	m	760
4080	Aluminium Channel	m	400
4380	Steel Corner	pc	1,500
4400	Corner Plate for Invisible Profile	pc	1,500
4461	Gasket	pc	400
4042	Aluminium U Profile	m	80
4043	Aluminium Chair Profile	m	80
4044	Aluminium F Profile	m	80
4211	Kingspan PalDuct PIR Adhesive	kg	90
4310	Aluminium Tape	roll	150
4250	Kingspan PalDuct Sealant	tube	90
4450	Reinforcement Bar in Aluminium	m	120
4454	Reinforcement Disc	pc	200

Prestige Projects



Project Name: The Heart of Europe
Location: Dubai, United Arab Emirates
Building Use: Hotels, Restaurants & Leisure
Product: Kingspan PalDuct PIR System



Project Name: Aldar Headquarters
Location: Abu Dhabi, United Arab Emirates
Building Use: Offices
Product: Kingspan PalDuct PIR System



Project Name: Arabian Ranches Golf Club
Location: Dubai, United Arab Emirates
Building Use: Leisure
Product: Kingspan PalDuct PIR System

Contact Details

Middle East

Kingspan Insulation LLC

PO Box 113826 | Dubai Investment Park 2
Dubai | UAE

T: +971 (0) 4 889 1000

F: +971 (0) 4 883 8515

E: info@kingspaninsulation.ae

www.kingspan.com/ae/en

Technical Service

Kingspan Insulation has one of the most technically advanced support services in the industry offering a full spectrum of advice, free of charge for all types of design projects.

The Kingspan Insulation technical team are continually updating their knowledge on building regulations, best practise, construction methods and the development of building materials to ensure the advice and services provided are always one step ahead.

Services available:

- U-value calculations;
- condensation/dew point risk calculations;
- advice on product selection and product data for the full range of Kingspan Insulation products;
- installation and fixing advice on all applications and products;
- specification and construction advice; and
- Tapered Roofing Design service.

Email: technical@kingspaninsulation.ae

Kingspan Insulation LLC reserves the right to amend product specifications without prior notice. Product thicknesses shown in this document should not be taken as being available ex-stock and advice should be sought directly from Kingspan Insulation LLC. The information, technical details and fixing instructions etc. included in this literature are given in good faith and apply to uses described herein. Recommendations for use should be verified as to the suitability and compliance with actual requirements, specifications and any applicable codes, laws and regulations. For other applications or conditions of use, Kingspan Insulation offers a Technical Advisory Service, the advice of which should be sought for uses of Kingspan Insulation products that are not specifically described herein or specifically required for your region.

To ensure you are viewing the most recent and accurate product information, please visit this link <https://www.kingspan.com/ae/en/products/ductwork/pre-insulated-duct/palduct-pir?s=d>

©Kingspan, PalDuct and the Lion Device are Registered Trademarks of the Kingspan Group plc in Egypt, Kuwait, Qatar, Saudi Arabia, South Africa, Turkey, United Arab Emirates and other countries. All rights reserved.

TM PalDuct is a Trademark of the Kingspan Group plc.

No rights can be derived from this document. Changes, typesetting and printing errors reserved. This version replaces all previous versions.

